

# Mobility scooters and powered wheelchairs on the road - some guidance for users

## Introduction

The Government is committed to helping people who have mobility difficulties to get around. This is so that people can remain active members of the community and maintain their independence. Traditionally, mobility scooters and powered wheelchairs have been used by those with mobility difficulties; as the population ages, more elderly people are likely to use mobility scooters, which are considerably less expensive than powered wheelchairs. Both provide a means of getting around the neighbourhood and to local shops, for those unable to walk or having difficulty in walking.

It is essential that users are able to keep themselves and other road users or pedestrians safe. They can do this by being aware of the road rules and using their vehicles responsibly and safely. The advice in this document is intended to raise awareness amongst those who use or are thinking of using a mobility scooter or powered wheelchair. It replaces any previous advice issued by the Department for Transport. For ease of reference mobility scooters and powered wheelchairs are referred to as mobility vehicles in this document.

## What is a mobility vehicle?

Manual and powered wheelchairs and mobility scooters are medical devices for those who cannot walk or who have difficulty walking. In law you will still find them called 'invalid carriages'. There are three types of 'invalid carriage' defined in 'The Use of Invalid Carriages on Highways Regulations 1988':

- Class 1 - manual wheelchairs, i.e. self-propelled or attendant-propelled, not electrically powered;
- Class 2 - powered wheelchairs and mobility scooters, intended for footpath or pavement use only with a maximum speed limit of 4 mph;
- Class 3 - powered wheelchairs and mobility scooters, for use on the road, with a maximum speed limit of 8 mph but with the facility to travel at 4 mph on a footpath or pavement.

Some other types of small electrically powered vehicles such as golf buggies look similar to mobility scooters. They are not 'invalid carriages' within the meaning of the 1988 Regulations. It may be illegal to use them on the public highway.

This document focuses on Class 2 and Class 3 vehicles.

## Can anyone use a mobility vehicle?

The law states that a Class 2 and Class 3 vehicle may only be used by a disabled person, or by a non-disabled person who is demonstrating a vehicle before sale, training a disabled user or taking the vehicle to or from a place for maintenance or repair. In addition, a Class 3 vehicle can only be used by a disabled person aged 14 or over. A disabled person in this context is someone with an injury, physical disability or medical condition which means that they are unable to walk or have difficulty in walking.

## Where can I use my mobility vehicle?

All vehicles can be used on footpaths, pavements, bridleways, and in pedestrian areas at a maximum speed of 4mph. Class 1 and 2 vehicles can be used on the road if a pavement is not available, or where it is necessary to cross the road.

Class 3 vehicles can be used on most roads at a maximum speed of 8mph. They cannot be used on motorways, in bus lanes (when in operation) or in "cycles only" cycle lanes. They should not be used on dual carriageways with a speed limit of over 50 mph. If they are, you must have an amber flashing light for safety reasons. It is advisable that you have an amber flashing light when used on all other dual carriageways.

## Can I take my vehicle on public transport?

Provided there is the space available, you can travel in your wheelchair (whether manual or powered) on buses and trains, so long as those vehicles are constructed or adapted to carry a 'reference' wheelchair; and that your wheelchair fits within the dimensions. Buses are restricted to one wheelchair space. Where any other passengers are occupying the wheelchair space, the driver should ask them to move to allow you to board. Please consider other passengers when manoeuvring onto a bus or train. A 'reference' wheelchair must comply with the basic dimensions set out in Annex **(A)**.

For rail travel, in some cases you must book a space on trains where there is limited wheelchair space provision, so it is advisable to contact the relevant train operating company in advance when planning a journey. You should ask the train operator to confirm that adequate ramps will be available at both ends of the journey.

Some smaller models of mobility scooter are accepted on some public transport vehicles, but you must contact the local transport operator to check. It is

important to remember that a mobility scooter may not have the same capacity as a wheelchair to manoeuvre into a wheelchair space.

The Confederation of Passenger Transport has published a non-statutory Voluntary Code of Best Practice for bus operators regarding the use and acceptance of Class 2 mobility scooters on low floor buses adapted to carry wheelchairs. Mobility scooters cannot be carried on coaches fitted with wheelchair lifts. (The Code is at Annex B).

All train operating companies will carry lightweight folded mobility scooters as luggage. More details on whether other types of scooters can be transported are provided by individual train operating companies. Contact National Rail Enquiries - [www.nationalrail.co.uk](http://www.nationalrail.co.uk) (go to Information for Disabled Passengers) or Tel: 08457 48 49 50.

To take a mobility vehicle in a taxi, the local taxi company should be contacted to check whether their taxis are suitable to carry your type of mobility vehicle.

## Do I need to register my mobility vehicle?

Mobility vehicles are not legally defined as motor vehicles and, therefore, the user is not required to have a driving licence or to take a test. The vehicles themselves are not subject to Vehicle Excise Duty ('road tax'). However, both new and used Class 3 vehicles have to be registered with the Driver and Vehicle Licensing Agency (DVLA) and display a 'nil duty' tax disc. Further information can be obtained from the DVLA Contact Centre – Tel: 0300 790 6802.

## Should I have insurance?

Although it is not a legal requirement, it is strongly advised that people take out insurance to cover personal safety, other people's safety and the value of the vehicle. It will be important to check whether household insurance provides cover to use a vehicle on the public highway, and whether your household insurance covers storage or parking for your vehicle at home.

## What features are legal requirements?

Mobility scooters and powered wheelchairs must have certain construction features, including:

Construction features	Class 2	Class 3
Max unladen weight	113.4 kg (248 lbs)	150 kg (330 lbs)
Max pavement speed	4 mph (6.4 kmph)	4 mph (6.4 kmph)
Max road speed	Not applicable	8 mph (12.8 kmph)
Speed device and speed indicator (i)	Not applicable	required
Max width	Not applicable	0.85 metres (2'9")
Lights	Lamps and reflectors required only if used between dusk and dawn	(i) front and rear lights and reflectors, and direction indicator, which are able to operate as a hazard warning signal; (ii) an amber flashing light if used on a dual carriageway
Rear view mirror	Not applicable	Required
Audible warning instrument (horn)	Not applicable	Required
Braking requirement	Must be capable of stopping in all conditions in reasonable time and distance, and of being held on a gradient of at least 1 in 5.	Must be capable of stopping in all conditions in reasonable time and distance, and of being held on a gradient of at least 1 in 5.

(i) *Speed device: means a device to limit the maximum speed to 4 mph, operable by the user.*

## What about two person vehicles?

Two person mobility vehicles are not permitted to be used on the public highway (i.e. on a pavement or road). They can be used on private land with the permission of the land owner.

It is not permitted to carry anyone else on a mobility vehicle e.g. a baby or a small child. However, the law does not explicitly state that a parent or guardian carrying a child in a pouch or a sling on their person, as an adult who was not disabled would do, is unlawful.

## Choosing the right vehicle

When considering using a mobility vehicle, it is important to get expert advice to make sure it meets your needs, particularly if you are choosing a vehicle for the first time. We recommend always going to an approved supplier who should also assess your needs and help you to choose the right vehicle. It is important to try out a vehicle before buying, to ensure you have the strength, control and confidence to use it. It may be possible to arrange a home visit to see how suitable a scooter or wheelchair might be for your home; in particular, if there are suitable storage and battery charging facilities. Consider whether your weight and build affects the stability of a vehicle; if you have limitations in using your hands you should consider if the controls are suitable. You should also consider whether you will be able to get on and off the vehicle easily. You will need to decide how far you intend to travel and what difficulties your typical journey might entail; for instance, uneven surfaces, high kerbs or steep hills.

Vehicles vary in design, size, features and price, and using a mobility vehicle requires a combination of sight, strength, co-ordination, balance and concentration. Before acquiring, and during ownership of a vehicle, you should undertake an assessment with your dealer/supplier. You may also wish to ask your doctor or an occupational therapist to provide a check.

It is not always advisable to buy a vehicle online as it may not be suitable for your needs. If you are buying a second hand vehicle, it is important you have the vehicle checked for any possible faults, and that you ensure you obtain the handbook. All vehicles should bear the CE mark to indicate conformity with European standards. If you are in doubt about a supplier, contact the British Healthcare Trades Association (BHTA) for advice. (See Useful Addresses at the end of this guide).

The sort of questions to ask the dealer/supplier about the vehicle are:

- How much does it cost?
- What is covered by the warranty?
- Is training provided or do you know of any training available locally?
- Where can I find out further information on the vehicle?
- Where can I best use this vehicle?
- Is the wheelchair "reference" wheelchair size?
- Can it be transported in a car or on public transport?
- What equipment does it come with?
- What about servicing; is there a breakdown recovery service?

## What should I do to prepare myself for going out on my vehicle?

If you are using a mobility vehicle for the first time, or if it is a while since you have driven on the road, you are strongly advised to get some training to ensure that you can steer and control the vehicle properly, especially on uneven surfaces. Your assessment should have involved checking your eyesight, reaction time, balance and posture, ability to sit for long periods, concentration and ability to get on and off the vehicle. You may also want to consider having a regular review of your driving skills.

Although there are no legal eyesight requirements, good vision is important to drive a mobility vehicle safely and you should be able to judge distances, recognise obstacles and hazards, and be able to see pedestrians and other road users. Poor eyesight could be a contributory factor in an incident and could make you liable for a compensation claim. Vision can change with age and you are recommended to have regular sight tests. Therefore, you should have a minimum visual acuity of 6/24.

When choosing your mobility vehicle you will be asked about your vision. If you are eligible to be registered as severely sight impaired (blind), you should not drive a mobility vehicle as this would put yourself and others at risk. If you are eligible to be registered as sight impaired (partially sighted), you should speak to your optometrist or doctor.

If you regularly take medication that makes you drowsy, you should consider whether it would be safe to use a mobility vehicle. If you are in any doubt, consult your doctor. You should not use a mobility vehicle if you have been drinking alcohol.

For details of training courses, please contact your local authority or local police force. See also Useful Addresses at the end of this guide. Some transport operators also provide training if you are intending to take your vehicle on a bus or train.

## What 'rules of the road' should I follow?

The Highway Code now has a section on powered wheelchairs and mobility scooters. This is reproduced at Annex **(C)**. You should also look at a current edition of the Highway Code and become familiar with the various traffic signs and signals that you will come across when you are using your vehicle.

In addition, be careful not to overload your vehicle, for instance with shopping bags. It may become unstable and difficult to control. Try to carry heavy loads

in the centre of the vehicle to maintain stability. Always check the manufacturer's guidance or operator's manual for load limits and advice about your particular scooter or powered chair. Never hang carrier bags on or from the vehicle's tiller or handlebars. Take extra care when going around a sharp corner, a camber or a bend, and slow down if necessary. If the vehicle has a lap belt fitted to it, always use it - even for short journeys.

Always plan your journeys carefully, and whenever possible try to stick to the pavement. If you have to use the road, try to reach your destination without having to negotiate major roundabouts, rush-hour traffic, or busy roads. Familiarise yourself with the facilities in your local area, such as dropped kerbs, which will help you to cross roads. However, if the situation on the road does become too daunting, you can always switch to pavement mode (4 mph) and move to the footpath until you feel confident enough to rejoin the traffic. Remember, care should also be taken when using the pavement. Pedestrians may not hear a vehicle approaching and might, for instance, change direction without warning. Ensure you take a charged mobile phone with sufficient credits on it - in case of an emergency.

If you are travelling at night, lights must be used, for both Class 2 and Class 3 vehicles, but remember it is always a good idea to be as conspicuous as possible. You could wear a fluorescent jacket or attach reflective markings to make you and your vehicle more conspicuous.

## How can I keep my vehicle roadworthy?

It is essential that you keep your vehicle in good working order in accordance with the manufacturer's recommendations. Vehicle suppliers should be able to answer any questions you might have about the maintenance of specific models.

It is essential to keep your battery in good working order. Your dealer will advise on how often it should be charged, but never start an unfamiliar journey without a fully charged battery, and be aware of your vehicle's range on a fully charged battery. Check your vehicle's tyre pressure regularly. How far and how long you can travel on a charge will depend on your weight, the surface on which you are riding, if you are using lights and having the tyres at the correct pressure. Lighting equipment should be kept clean and in good working order. If you are using weather protective capes, or scooter covers, you must ensure nothing obscures your visibility. Windows, windscreens and mirrors should also be clean and clear of obstructions for good all-round vision. It is important that your vehicle undergoes a thorough safety check at least once a year.



## What happens if I break down?

It is important to know what service is available in the event of a breakdown and you are away from home. If hiring, check whether breakdown insurance is already in place. If buying, check what insurance is available, how much it costs and whether it extends to breakdown off road.

## Useful Addresses

**If you have any questions about this guidance, please contact:**

Department for Transport  
Sustainable Travel and Equalities  
Zone 2/15  
Great Minster House  
33 Horseferry Road  
London, SW1P 4DR.

Tel: 020 7944 2046

**If you require further information about suppliers, please contact:**

British Healthcare Trades Association (BHTA)  
New Loom House  
Suite 4.06  
101 Back Church Lane  
London, E1 1LU.

Tel: 020 7702 2141 Fax: 020 7680 4048  
Email: [bhta@bhta.com](mailto:bhta@bhta.com) Web: [www.bhta.net](http://www.bhta.net)

**For further information about training facilities, please contact:**

The Forum of Mobility Centres  
c/o Providence Chapel  
Warehorne  
Ashford  
Kent, TN26 2JX

Tel: 0800 559 3636 (free phone number - between 9.00 and 5.00pm Mondays to Fridays)  
Email: [mobility@rcht.cornwall.nhs.uk](mailto:mobility@rcht.cornwall.nhs.uk) Web [www.mobility-centres.org.uk](http://www.mobility-centres.org.uk)

National Federation of Shopmobility  
PO Box 6641  
Christchurch  
BH23 9DQ.

Tel: 0845 644 2446.  
Email: [info@shopmobilityuk.org](mailto:info@shopmobilityuk.org) Web: [www.shopmobilityuk.org](http://www.shopmobilityuk.org)

For general information about mobility vehicles, contact:

Disabled Motoring UK  
Ashwellthorpe  
Norwich  
NR16 1EX.

Tel 01508 489449

Email: [info@disabledmotoring.uk](mailto:info@disabledmotoring.uk)

[www.disabledmotoring.uk](http://www.disabledmotoring.uk)

## Annex A - Reference Wheelchair dimensions.

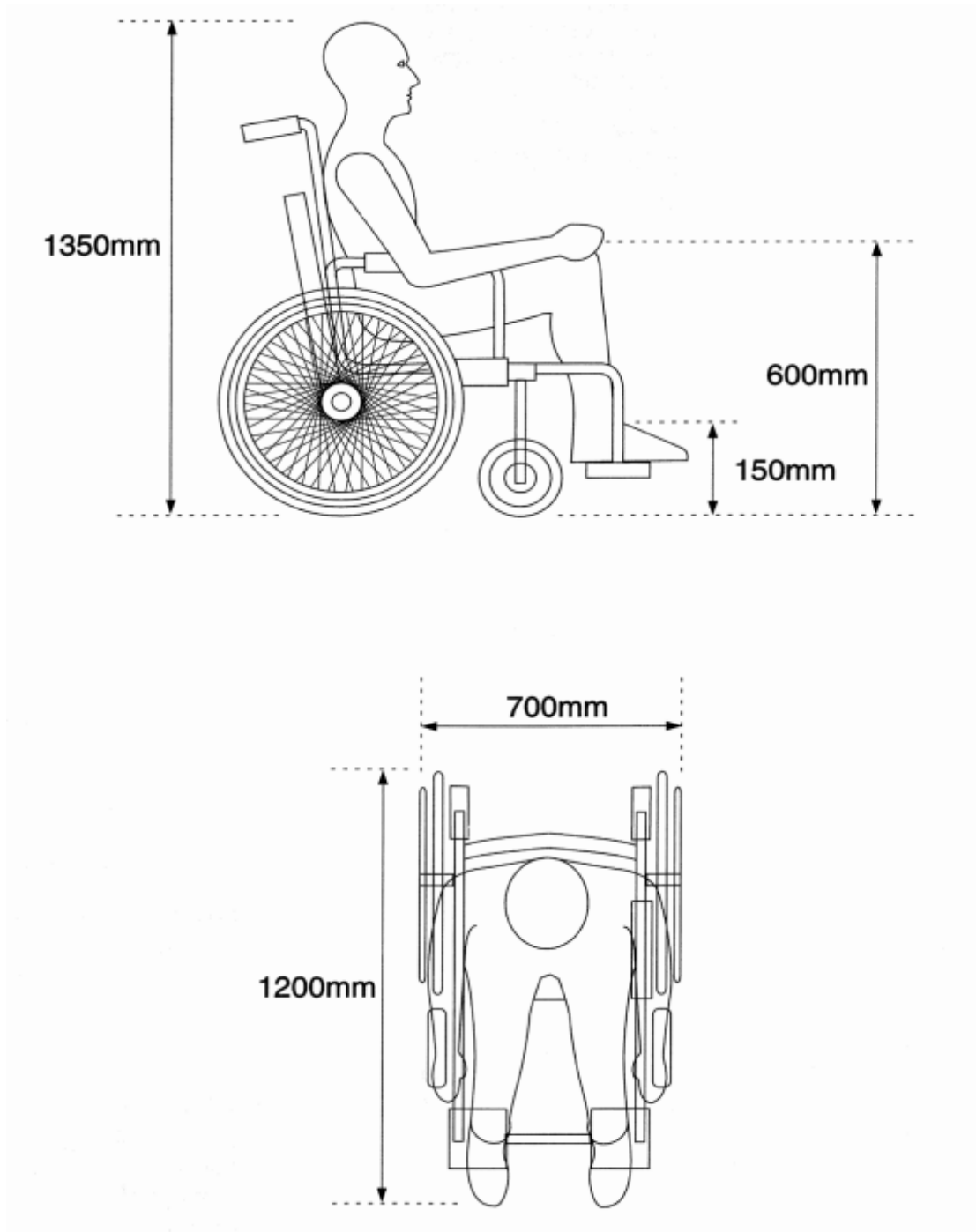

# Annex B - Confederation of Passenger Transport

## Voluntary Code of Best Practice

The Confederation of Passenger Transport UK (CPT) is recognised by Government as the voice of the bus, coach and light rail industries, and the focus for consultation on national and international legislation, local regulations, operational practices and engineering standards.

CPT Code for the use and acceptance of Mobility Scooters on low floor Buses adapted to carry wheelchairs:

Bus operators are committed to making scheduled bus services accessible to as many people as possible and this code is designed to assist in helping operators in developing a policy to enable mobility scooters to be used on their services. Mobility scooters are used by an increasing proportion of the population and are not built to recognised common standards.

This code has been developed jointly by CPT and the Department for Transport and is designed to be the industry standard for the carriage of mobility scooters on scheduled bus services outside London. Its aim is to reduce the scope for “on the bus” disagreement and disputes.

Operators who adhere to this code should make this publicly known, particularly to groups representing people with mobility difficulties.

### Requirements for Operators

There is no legal requirement to carry Mobility Scooters which are carried at each operator’s individual discretion.

“Class 2” scooters with 3 or 4 wheels will be accepted provided they are no more than 600mm wide and 1000mm long, with a turning radius not exceeding 1200mm, and subject to the other criteria set out herein. For ease of recognition, drivers should be issued with a handy card “recognition guide” to identify “Class 2” and “Class 3” scooters.

The weight of the scooter plus occupant must be within the safe working limit (SWL) of the ramp fitted to the vehicle.

As a general rule the ramps fitted to vehicles have a safe working limit of 300kg. The SWL is identified on the bulkhead in each vehicle or on the actual ramp itself. “Class 2” scooters generally weigh 65 kg, leaving 235kgs (approx 37 stones) allowance for the occupant. It should be for the driver’s discretion to confirm that the mobility scooter and occupant are within the SWL for the ramp.

If the driver considers the weight to be in excess of this, then the intending passenger should be politely refused entry onto the vehicle and offered an appropriate explanation.

“Class 3” scooters are larger and are capable of travelling at 6-8 mph. These are not designed to be carried by bus and should therefore be refused for carriage. They can easily be identified, as they must be fitted with front/rear lights, hazard warning lights, and a manual brake.

Operators must ensure that Mobility Scooter users have their scooter assessed and approved as suitable for carriage on their vehicles. This approval needs to cover both the design of the scooter and the ability of the user to control and manoeuvre it safely.

Approval should be issued in the form of a credit card sized photographic “permit for travel” which should be for a fixed duration (not more than 5 years) as users’ health and abilities may alter over time. The permit will also contain the conditions of use and the user should show this permit to the driver on boarding the vehicle. This standard permit once accepted and issued by one operator should be accepted by all other operators who have signed up to the code.

#### Requirements for Users of Mobility Scooters

All users of mobility scooters who are prospective passengers must obtain prior approval of operators and obtain a standard “permit for travel” prior to their scooter being carried on any bus.

Mobility scooter users must be assessed and receive on-bus training from the operator before travelling on the bus for the first time.

As part of this training, users should be advised about the prevalence of low floor vehicles with ramps and advised that where such a vehicle is not available and a step entry vehicle is in service, it will not be possible for them to be transported.

The user must be trained by the operator in manoeuvring up and down the ramp, and within the vehicle. The ramp must be accessed head on when boarding and alighting the vehicle to reduce the risk of accidents. Only once the operator is satisfied that the user can perform these tasks safely and in a reasonable period of time should the “permit to travel” be issued to the user.

Once on board, users should put their mobility scooter in the designated wheelchair space, reversed up to the backrest. The scooter motor must be switched off and the scooter parked in gear to avoid movement. If the

wheelchair space is already occupied by a wheelchair, it will not be possible for the scooter user to travel.

It is a requirement that the passenger remains on the mobility scooter once it is parked in the designated wheelchair space, using the handrails provided to assist with safety and stability.

The user should be advised that the scooter will only be carried provided that it does not pose a danger to other occupants of the vehicle. The user should be advised that the scooter must therefore be maintained in good working order, that no battery or electrical or mechanical equipment should be exposed or be leaking any fluid, is not modified or customised such that it represents an obstruction or other hazard to other passengers, and that the scooter should not be overloaded with any items which would make the scooter unstable (e.g. shopping bags).

Bus operators reserve the right to withdraw the permit to travel in the event of misuse of the mobility scooter, by the holder of the permit, which results in damage or injury to other passengers and/or the vehicle.

#### Driver Training for all PCV drivers

The acceptance of mobility scooters on low floor buses adapted to carry wheelchairs must be included in any disability awareness training course delivered as part of Driver CPC.

Drivers should be:

advised of the permit system and the assessment process that each mobility scooter has gone through before being issued with a permit to enable them to use the mobility scooter on low floor buses.

advised of the technical capabilities of "Class 2" mobility scooters and which ones are acceptable for use on the vehicle.

issued with a handy "recognition guide" showing the common types of accepted "Class 2" scooters, and the prohibited "Class 3" designs.

reminded of the importance of parking the vehicle at bus stops parallel and close to the kerb to enable the safe use of the vehicle ramp.

trained in a safe system of work for safely deploying and stowage of the vehicle ramp.

advised of the emergency procedures to be adopted in the event of the customer getting into difficulties whilst trying to board or alight from the vehicle.

reminded of the code of conduct regulations which states they should ask customers occupying the wheelchair and buggy space to move if a wheelchair user, mobility scooter or buggy user wishes to board and occupy this space.

reminded to advise customers before they board with a mobility scooter, that they must approach the ramp head on when boarding or alighting to eliminate the risk of tipping.

Note: users of wheelchairs which conform to the standard reference size will continue to be carried on suitable low-floor vehicles subject to the designated space being available.



## Annex C - Extracts from the Highway Code

***Rules for users of powered wheelchairs and mobility scooters (36-46) -  
(Called Invalid Carriages in law)***

36: There is one class of manual wheelchair (called a Class 1 invalid carriage) and two classes of powered wheelchairs and powered mobility scooters. Manual wheelchairs and Class 2 vehicles are those with an upper speed limit of 4 mph (6 km/h) and are designed to be used on pavements. Class 3 vehicles are those with an upper speed limit of 8 mph (12 km/h) and are equipped to be used on the road as well as the pavement.

37: When you are on the road you should obey the guidance and rules for other vehicles; when on the pavement you should follow the guidance and rules for pedestrians.

#### On pavements

38: Pavements are safer than roads and should be used when available. You should give pedestrians priority and show consideration for other pavement users, particularly those with a hearing or visual impairment who may not be aware that you are there.

39: Powered wheelchairs and scooters **MUST NOT** travel faster than 4 mph (6 km/h) on pavements or in pedestrian areas. You may need to reduce your speed to adjust to other pavement users who may not be able to move out of your way quickly enough or where the pavement is too narrow.

40: When moving off the pavement onto the road, you should take special care. Before moving off, always look round and make sure it's safe to join the traffic. Always try to use dropped kerbs when moving off the pavement, even if this means travelling further to locate one. If you have to climb or descend a kerb, always approach it at right angles and don't try to negotiate a kerb higher than the vehicle manufacturer's recommendations.

#### On the road

41: You should take care when travelling on the road as you may be travelling more slowly than other traffic (your machine is restricted to 8 mph (12 km/h) and may be less visible).

42: When on the road, Class 3 vehicles should travel in the direction of the traffic. Class 2 users should always use the pavement when it is available. When there is no pavement, you should use caution when on the road. Class 2 users should, where possible, travel in the direction of the traffic. If you are travelling at night when lights MUST be used, you should travel in the direction of the traffic to avoid confusing other road users.

43: You MUST follow the same rules about using lights, indicators and horns as for other road vehicles, if your vehicle is fitted with them. At night, lights MUST be used. Be aware that other road users may not see you and you should make yourself more visible - even in the daytime and also at dusk - by, for instance, wearing a reflective jacket or reflective strips on the back of the vehicle.

44: Take extra care at road junctions. When going straight ahead, check to make sure there are no vehicles about to cross your path from the left, the right, or overtaking you and turning left. There are several options for dealing with right turns, especially turning from a major road. If moving into the middle of the road is difficult or dangerous, you can

- *stop on the left-hand side of the road and wait for a safe gap in the traffic*
- *negotiate the turn as a pedestrian, i.e. travel along the pavement and cross the road between pavements where it is safe to do so. Class 3 users should switch the vehicle to the lower speed limit when on pavements*

If the junction is too hazardous, it may be worth considering an alternative route. Similarly, when negotiating major roundabouts (i.e. with two or more lanes) it may be safer for you to use the pavement or find a route which avoids the roundabout altogether.

45: All normal parking restrictions should be observed. Your vehicle should not be left unattended if it causes an obstruction to other pedestrians - especially those in wheelchairs.

46: These vehicles MUST NOT be used on motorways (see Rule 253). They should not be used on unrestricted dual carriageways where the speed limit exceeds 50 mph (80 km/h) but if they are used on these dual carriageways, they MUST have a flashing amber beacon. A flashing amber beacon should be used on all other dual carriageways (see Rule 220).

- *[The Highway Code is available on-line at: <http://www.direct.gov.uk> ]*

The Department for Transport has actively considered the needs of blind and partially sighted people in accessing this document. The text will be made available in full on the Department's website in accordance with the W3C's Web Content Accessibility Guidelines. The text may be freely downloaded and translated by individuals or organisations for conversion into other accessible formats. If you have other needs in this regard please contact the Department.

Department for Transport  
Great Minster House  
76 Marsham Street  
London SW1P 4DR  
Telephone 0300 330 3000  
Website [www.dft.gov.uk](http://www.dft.gov.uk)

© Crown copyright 2011

Copyright in the typographical arrangement rests with the Crown.

You may re-use this information (not including logos or third-party material) free of charge in any format or medium, under the terms of the Open Government Licence. To view this licence, visit [www.nationalarchives.gov.uk/doc/open-government-licence/](http://www.nationalarchives.gov.uk/doc/open-government-licence/) or write to the Information Policy Team, The National Archives, Kew, London TW9 4DU, or e-mail: [psi@nationalarchives.gsi.gov.uk](mailto:psi@nationalarchives.gsi.gov.uk).

Where we have identified any third-party copyright information you will need to obtain permission from the copyright holders concerned.

The information in this document is for general guidance only. It does not constitute legal or other professional advice. Because it is intended only as a general guide, it may contain generalisations. You should obtain professional advice if you have any specific concerns.